



V8M

6x8" Mini Slim Powered Subwoofer

6x8寸迷你超薄低音音箱

User's Manual/使用说明

Panel controls and features

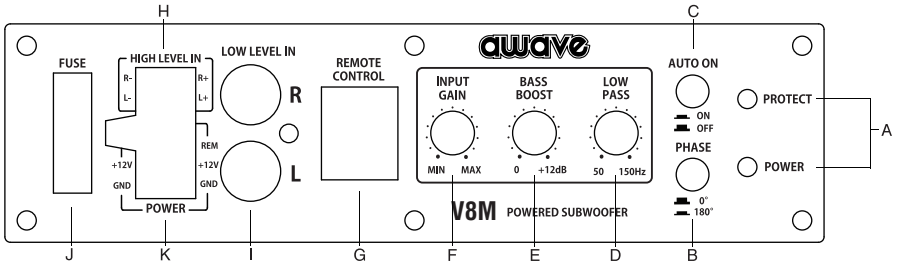

A. POWER STATUS LED

This bi-color LED glows green when power is on and no problems are present. If one of the protection circuits comes on, it will change to red.

B. PHASE SHIFT

Use this switch to help compensate for time alignment problems in the system. Such problems usually result from having the subwoofer at a different distance from the listener than the other speakers in the system.

C. AUTO POWER ON

The AUTO POWER ON(ON/OFF) is for high level (speaker-level) connections. When the switch is in the "ON" position, the subwoofer AUTO POWER ON when there is signal input. If the amplifier detected no signal input, the amplifier will auto turn off. If you prefer to use the remote turn on/off connection, the switch is in the OFF position.

Note: Please connect the remote terminal to the remote output of head unit as Fig.4. When you hear the unit turn ON/OFF POP noise from the subwoofer.

D. LOW PASS FILTER

This control permits you define the frequency range you want the subwoofer amplifier to receive. The subwoofer will reproduce all sound BELOW the frequency you set.

Note: The low pass filter frequency can be higher or lower than the standard. There have +/-20% tolerance.

E. BASS BOOST

The BASS BOOST feature will increase the sound level in the bass frequencies.

F. INPUT GAIN CONTROL

After you have installed your system, turn this control to minimum.

Turn the head unit on (and the subwoofer will turn on via the remote connection). Turn the head unit volume to about 2/3 full level.

Slowly turn up the subwoofer input gain control until you hear a small amount of distortion. Then reduce the level until the distortion is completely gone. Level the control at this setting.

G. REMOTE LEVEL CONTROL PORT

Attach the included remote level control to control the volume level of the subwoofer independently.

H. HIGH LEVEL (speaker level) INPUTS

If your head unit does not have RCA outputs you can use the speaker outputs for the audio source for the subwoofer. Use the supplied cable and wire harness and connect the outputs properly as shown in the connection diagram in this manual.

I. LOW LEVEL RCA INPUTS

Low level inputs are the recommended way to introduce the audio signal to the subwoofer if RCA outputs are present on your head unit or other signal source (such as a sound processor).

J. FUSE

Do not use a fuse with a different value and NEVER replace the fuse with a wire or coin.

K. POWER INPUT TERMINAL

Low Level Input Wiring

Low-level (RCA) input wiring is preferred for best audio performance. Most trunk or hatchback installations will require a 15-20 feet RCA cable, while pickup trucks and under-seat installations will require a 6-12 feet RCA cable. Always use a high quality cable.

NOTE: Do not connect BOTH the high level and low level inputs from your receiver to your amplifier at the same time!

Fig.1

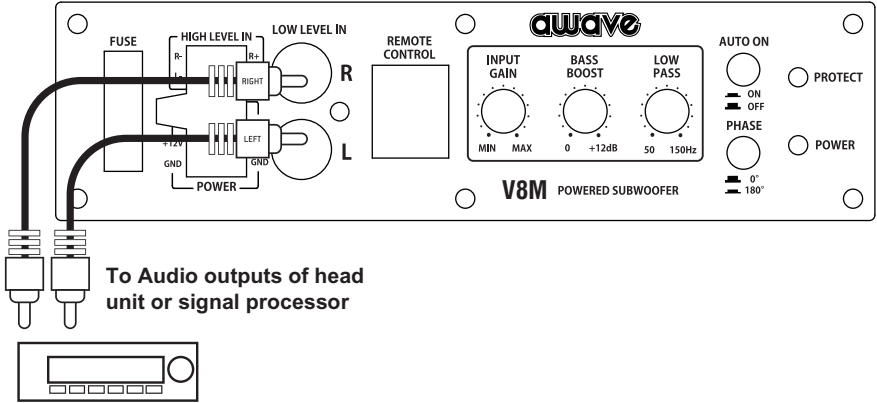

High Level Input Wiring

The high level input(s) should only be used when your receiver lacks RCA outputs. If the RCA outputs are not present, connect the speaker outputs from the receiver to the high level input connector of the amplifier. Be sure to observe polarity to avoid audio phase problems.

NOTE: Do not connect BOTH the high level and low level inputs from your receiver to your amplifier at the same time!

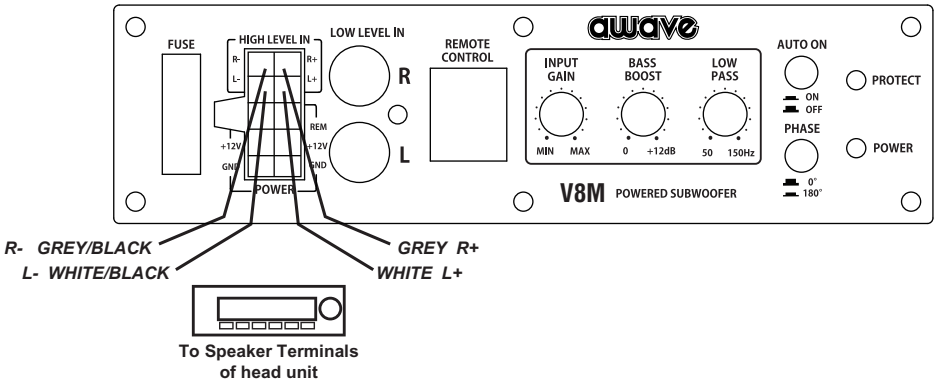

Power Connections

Connect the ground terminal to the closest point on the chassis of the vehicle. Keep this ground wire to less than 39" (100 cm) in length. Use 8 gauge (or heavier) wire.

Connect the remote terminal to the remote output of head unit using 16 gauge (or heavier) wire.

Connect an empty fuse holder within 18" (45 cm) of the car battery, and run 8 gauge (or heavier) cable from this fuse to the amplifier location. Then connect the fuse holder to the "BATT+" (+12V) connection on the subwoofer rear panel.

Fig.3

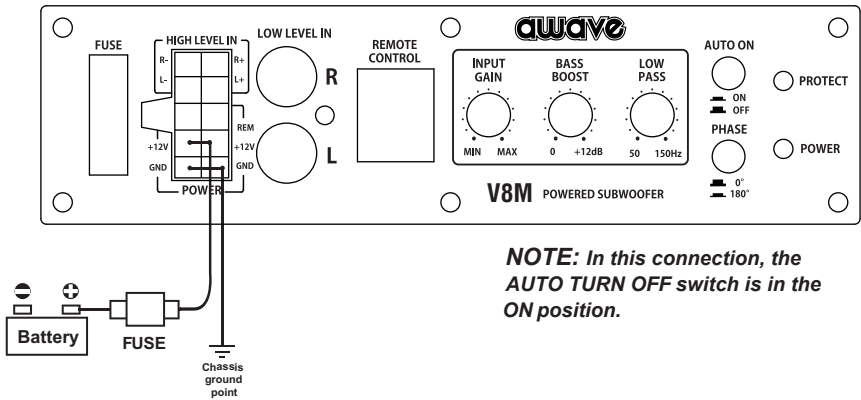
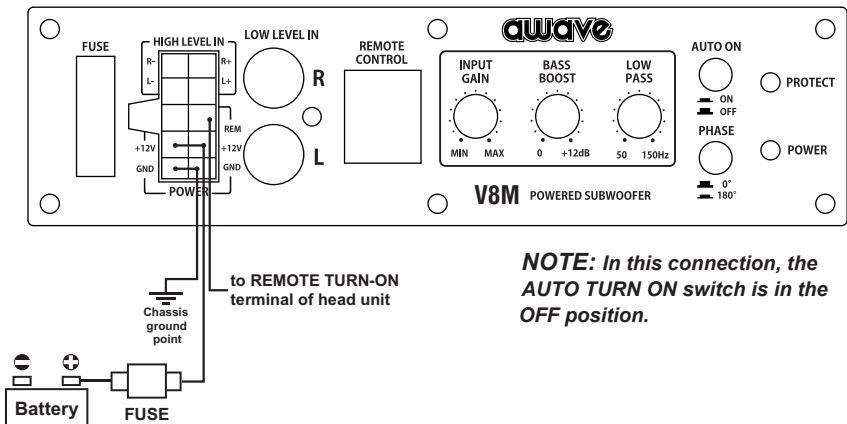
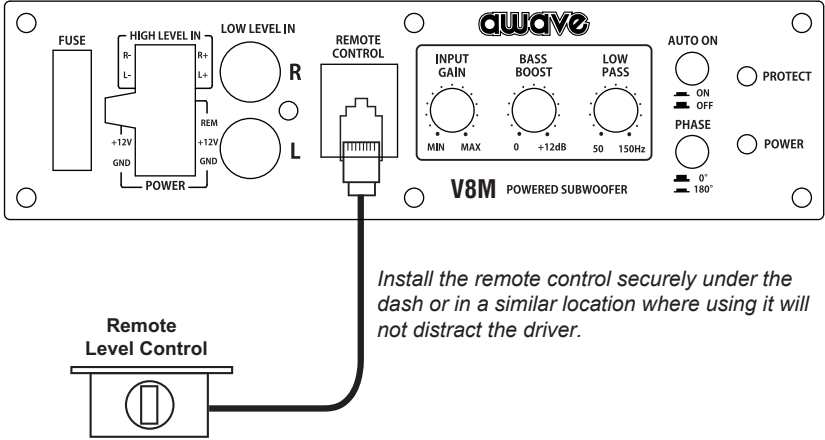

Fig.4



Remote Level Control Connection

Fig.5



Specifications

MODEL:	V8M
RMS power	100W
THD	<0.4%
Signal-to-noise ratio	>90dB
Frequency response	20Hz - 150Hz
Input sensitivity, high level	1.0V
Input sensitivity, low level	300mV
Low Pass Filter	50Hz - 150Hz
Bass Boost	0 to + 12dB
Subsonic Filter	20Hz
Fuse rating	20A
Subwoofer	6x8inch,4ohm
Dimensions(L x W x H) mm	260 x 195x 72

All specifications subject to change without notice.

Troubleshooting

If you experience operation or performance problems with this product, compare your installation with the electrical wiring diagram on the previous pages. If problems persist, read the following troubleshooting tips which may help eliminate the problems.

SYMPTOM	POSSIBLE REMEDY
Amplifier will not power up.	<p>Check to make sure you have a good ground connection.</p> <p>Check that the Remote Input (Turn-On) has at least 5VDC.</p> <p>Check that there is battery power on the (+) terminal.</p> <p>Check that there is at least 12v.</p> <p>Check all fuse, replace if necessary.</p> <p>Make sure that the Protection LED is not illuminated. If it is lit, shut off the amplifier briefly, and then repower it.</p>
Protection LED comes on when amplifier is powered up	<p>Check for short circuits on speaker leads.</p> <p>Turn down the volume control on the head unit to prevent overdriving.</p> <p>Remote speaker leads, and reset the amplifier. If the Protection LED still comes on, then the amplifier is faulty and needs servicing.</p>
No output.	<p>Check that all fuses are OK.</p> <p>Check that unit is properly grounded.</p> <p>Check that the Remote Input (Turn-On) has at least 5VDC.</p> <p>Check that the RCA audio cables are plugged into the proper inputs.</p> <p>Check all speaker wiring.</p>
Low output.	<p>Reset the Level Control.</p> <p>Check the Crossover Control settings.</p>
High hiss in the sound.	<p>Disconnect all RCA inputs to the power sub's control panel. If the hiss disappears, then plug in the component driving the amplifier and unplug its inputs. If the hiss disappears at this point, go on until the faulty/noisy component is found.</p> <p>It is best to set the amplifier's input level control as low as possible. The best subjective signal-to-noise ratio is achieved in this manner. Try to set the head unit as high as possible (without distortion) and the amp input level as low as possible.</p>
Squealing noise is present.	<p>Check for improperly grounded RCA interconnects.</p>
Distorted sound.	<p>Check that the Input Level Control is set to match the signal level of the head unit. Always try to set the Input Level as low possible.</p> <p>Check that all crossover frequencies are properly set.</p> <p>Check for short circuits on the speaker leads.</p>
Amplifier gets very hot.	<p>Check that the minimum speaker impedance for the amp model is correct.</p> <p>Check that there is good air circulation around the amp. In some applications, it may be necessary to add an external cooling fan.</p>
Engine noise (static type)	<p>This is usually caused by poor quality RCA cables, which can pick up radiated noise. Use only the best quality cables, and route them away from power cables.</p>
Engine noise (alternator whine)	<p>Check that the RCA grounds are not shorted to the vehicle chassis</p> <p>Check that the head unit is properly grounded.</p>

面板控件和功能

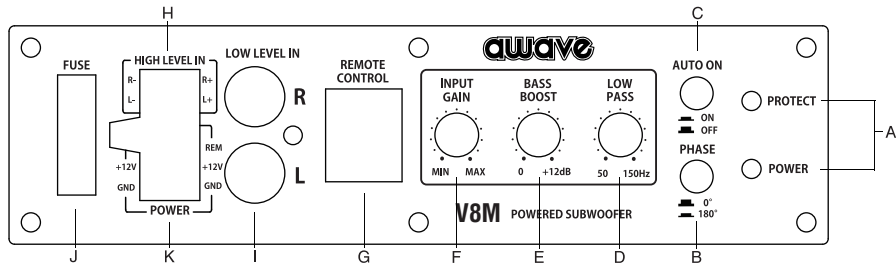

A. 电源和保护指示灯

B. 相位转换开关

C. 自动开关机控制开关

注意：开关主机时，如果听到有开关机冲击声，此时自动开关机开关要设定在“OFF”位置。改用主机的REMOTE线来控制开关机。

D. 低音滤波器电位器

注意：低通滤波器的实际频率有可能高于或低于设定值，误差在±20%左右。

E. 低音提升电位器

F. 音量电位器

G. 远程低音音量控制端口

H. 高电平输入端口

I. 低电平输入端口

J. 保险丝插座

K. 电源输入端子

低电平输入连接方式

Fig.1

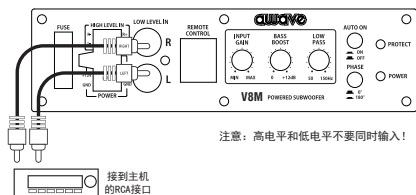

高电平输入连接方式

Fig.2

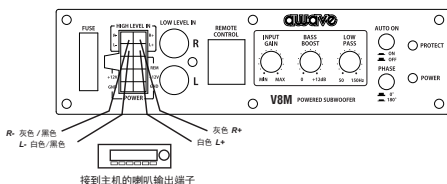

电源输入连接方式

方式一：

Fig.3

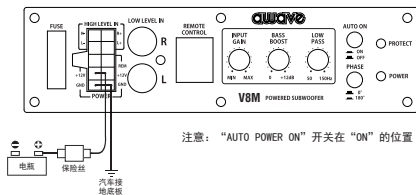

方式二：

Fig.4

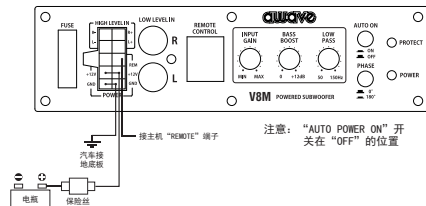

远程电平控制连接

Fig.5

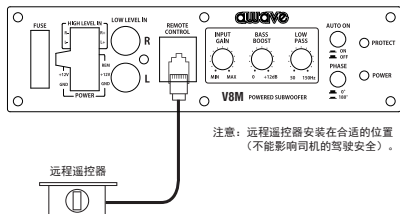

产品规格	V8M
额定功率	100W
总谐波失真	<0.4%
信噪比	>90dB
频率响应	20Hz - 150Hz
高电平输入灵敏度	1V
低电平输入灵敏度	300mV
低通滤波器	50Hz - 150Hz
低音提升	0 to + 12dB
高通滤波器	20Hz
保险丝额定值	20A
主动低音喇叭	6x8inch,4ohm
尺寸(长 x 宽 x 高) 毫米	260 x 195 x 72

所有规格如有变更，恕不另行通知。

故障排除

故障现象	故障原因
产品不能启动	<ol style="list-style-type: none"> 1.检查功放电源线是否连接良好。 2.检查电瓶正极电压是否加在功放的电源端子正极。 3.检查REMOTE电压不要低于5VDC。 4.检查电源端子正极电压不要低于+12V。 5.检查保险丝是否损坏（开路）。 6.确认保护指示灯是否亮起，如指示灯亮起则重新启动功放。
产品启动后保护指示灯亮起或过热保护	<ol style="list-style-type: none"> 1.检查喇叭接线端子是否短路。 2.调低音量电位器以防止过载保护。 3.卸掉喇叭连接线，重新启动功放，如保护指示灯亮则功放已损坏，需要维修。
产品无输出	<ol style="list-style-type: none"> 1.检查保险丝是否损坏（开路）。 2.功放是否正确接地。 3.功放启动电压不要低于5VDC。 4.检查RCA音频线或高电平输入线是否正确连接到功放。 5.检查喇叭线是否连接良好。
产品输出低	<ol style="list-style-type: none"> 1.重新设定音量电位器。 2.检查滤波器电位器是否在正确的位置。
播放音乐时有嘶嘶声	<ol style="list-style-type: none"> 1.断开功放的信号输入线，如果嘶嘶声消失就是信号源有问题，此时要确认信号线是否连接良好或信号线质量是否有问题，否则主机可能有问题。 2.尽可能把功放音量电位器开小，同时尽可能把主机音量开大（不要失真）。
有啸叫声	<ol style="list-style-type: none"> 1.检查RCA的地线是否连接好。
失真	<ol style="list-style-type: none"> 1.检查功放音量电位器是否太大了，功放音量电位器要配合好主机音量。 2.检查滤波器电位器大小是否合适。
产品发烫	<ol style="list-style-type: none"> 1.检查喇叭阻抗是否低于功放的标示阻抗。 2.检查功放的安装位置是否通风良好。
引擎声(静态)	<ol style="list-style-type: none"> 1.主要是RCA信号线质量太差的原因，要换用质量好的RCA信号线，并要远离电源线。
引擎声(发电机火花声)	<ol style="list-style-type: none"> 1.检查RCA信号线地线不能连接到汽车底盘。 2.检查主机是否正确接地。