

LIVE

LT 25

Tweeter

Guy Bonneville

BLAM

DRIVEN BY PASSION

- 25 mm (1")
- High quality soft dome tweeter
- N38 neodymium motor



TECHNICAL SPECIFICATIONS

Component	Tweeter	
Max power	100 W	
Nominal power	15 W	
Impedance	3 Ω	
Freq. Response	2.5 KHz - 25 KHz	
Sensitivity (2,83V/1m)	91.6 dB	
Magnet	Neodymium	
Magnet size Ø x h	18 x 3 mm	0.709 "x 0.118 "
Total driver displacement	-	-
Weight of one component	0.096 kg	0.212 lb
Voice coil Ø	25 mm	0.984"
Voice coil height	2 mm	0.079"
Cone	Soft	

Unit : mm

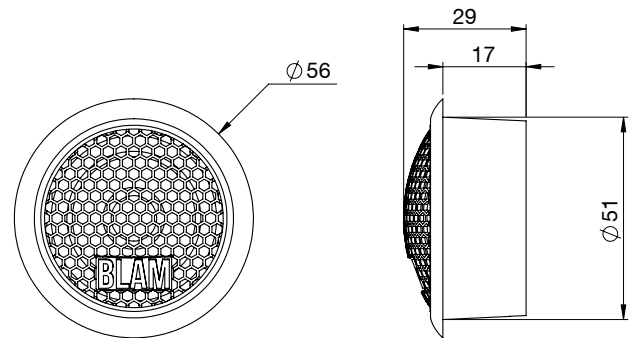

FREQUENCY RESPONSE / IMPEDANCE

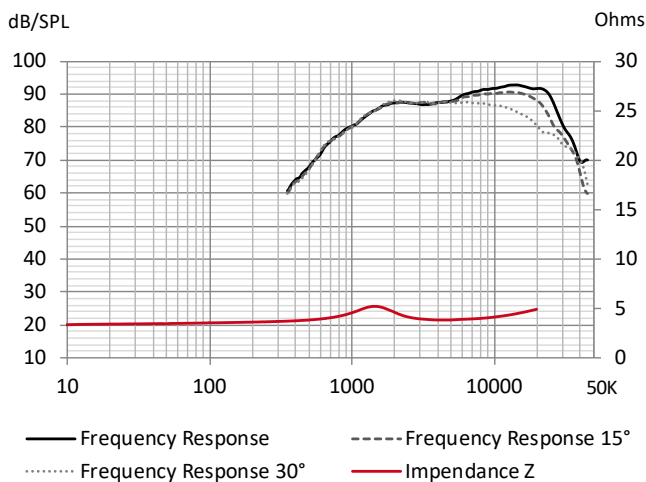

THIELE-SMALL PARAMETERS

effective Ø (d)	26 mm
Sd	5.31 cm ²
Xmax	-
Re	3.18 Ω
Fs	1501 Hz
Le	-
L2	-
Vas	-
Mms	-
Cms	-
BL	-
Qts	-
Qes	-
Qms	-
Sensitivity (dB/W/m)	87.6 dB

contact@blam-audio.fr
www.facebook.com/blamaudio

www.blam-audio.com