

REFERENCE[®]

1000s

1200s



 Infinity[®]

THANKYOU for choosing an Infinity[®] Reference[®] Series 1000s or 1200s subwoofer. These Reference subwoofers are designed to suit a broad range of car audio applications and can be used in a wide variety of enclosure types to produce extended, powerful bass in a limited amount of vehicle space. To get the most performance from your new subwoofer, it is strongly recommended that you have a qualified professional install your 1000s or 1200s subwoofer. Although this manual does provide general instructions about installing these Reference Series subwoofers, it does not include enclosure construction details or exact installation methods for any particular vehicle. If you do not feel that you have the necessary experience, do not attempt the installation yourself, but instead ask your authorized Infinity dealer about professional installation options.

Remember to keep your sales receipt in a safe place, along with this manual, so that both are available for future reference.

BOX CONTENTS

- (1) 1000s or 1200s subwoofer
- (1) Owner's manual
- (1) Technical data sheet

WARNING

Playing loud music in a vehicle can hinder your ability to hear traffic and permanently damage your hearing. The maximum volume levels achievable by Infinity speakers when combined with high-power amplification may exceed safe levels for extended listening. Using low volume levels is recommended when driving. Infinity Systems accepts no liability for hearing loss, bodily injury, or property damage as a result of use or misuse of this product.

REPRODUCING BASS IN VEHICLES

Depending on the size of your vehicle's interior listening space, reproduced bass frequencies below 80Hz will be boosted by nearly 12dB per octave as frequency decreases. This phenomenon, known as the vehicle's transfer function (or cabin gain), plays an important role in shaping the subwoofer's frequency response in your vehicle. The enclosed technical data sheet includes frequency response graphs that show both the subwoofer's "in-car" response (which factors in this vehicle transfer function) and its "out-of-car" response (which does not).

SUBWOOFER ENCLOSURE TYPES

Reference 1000s and 1200s subwoofers are designed to perform best in moderately sized sealed enclosures, vented enclosures and prefabricated band-pass enclosures. Infinite-baffle mounting is possible, but the subwoofer's mechanical power handling will be reduced because there will be no volume of air to stiffen the subwoofer's suspension and prevent overexcursion. If you choose infinite-baffle mounting, consider the RMS and peak power-handling ratings to be half of what is listed in the specifications in this manual.

You should choose an enclosure type based on the amount of cargo space you can devote to the enclosure, the amount of power you will use to drive your subwoofer(s), and your listening habits.

SEALED ENCLOSURES

The air trapped inside a sealed enclosure is compressed when the subwoofer moves rearward and is rarefied when the subwoofer moves forward. In both cases, the air inside and outside the box will seek equilibrium by pushing and pulling on

the subwoofer cone. The result is a stiffer suspension when compared to the subwoofer operating in free air. This means that the subwoofer's cone will be harder to move at low frequencies, a condition which protects the subwoofer from physical overexcursion, but requires more power than other designs to achieve a given acoustic output.



See accompanying data sheet for specific enclosure dimension requirements.

SEALED-ENCLOSURE PERFORMANCE ADVANTAGES

- The in-vehicle performance will have the flattest overall frequency response.
- The in-vehicle response will have the widest bandwidth. (Usable low-frequency response inside the vehicle will be below 20Hz.)
- An optimum sealed enclosure will always be smaller than an optimum enclosure of another type.

SEALED-ENCLOSURE PERFORMANCE TRADE-OFFS

- An optimum sealed enclosure will have lower overall efficiency than an optimum enclosure of another type.
- A 1000s or 1200s subwoofer in an optimum sealed enclosure will require more amplifier power to achieve a given acoustic output than in an optimum enclosure of another type.

SEALED-ENCLOSURE CONSTRUCTION

Sealed-enclosure construction is straightforward and forgiving of errors in volume calculation, but air leaks should be avoided. Use medium-density fiberboard (MDF), glue and screws to construct the enclosure, and seal all joints with silicone caulk.

THE INFINITY RECOMMENDATION

1000s and 1200s subwoofers in sealed enclosures are recommended for enthusiasts who prefer accurate music reproduction and flat frequency response, for those who have a smaller space to devote to a subwoofer enclosure, and for those who have plenty of amplifier power devoted to driving the subwoofer. The sealed-enclosure design indicated on the technical data sheet accompanying this manual represents the best compromise between low-frequency extension and flat response.

VENTED ENCLOSURES

A vented enclosure acts like a sealed enclosure at frequencies above its tuned (resonance) frequency. At resonance (which is defined by the vent), the vent produces the majority of sound – the subwoofer cone is nearly stationary while the air inside the vent vibrates. This provides greater mechanical power handling at and above resonance, but reduced mechanical power handling below resonance. Since the subwoofer cone and voice coil don't move much at resonance, airflow across the voice coil is minimized and thermal power handling is reduced slightly at resonance.

Vented enclosures provide better efficiency in the 40Hz – 60Hz range, at the expense of sound output in the lowest octave (below 40Hz). The use of an infrasonic filter is recommended with vented enclosures. An optimum vented enclosure for a Reference Series subwoofer is larger than an optimum sealed enclosure.



See accompanying data sheet for specific enclosure dimension requirements.

VENTED-ENCLOSURE PERFORMANCE ADVANTAGES

- An optimum vented enclosure has greater efficiency and higher output in the 40Hz – 60Hz range than an optimum sealed enclosure.
- An optimum vented enclosure provides a greater sensation of bass than an optimum sealed enclosure.
- A 1000s or 1200s subwoofer in an optimum vented enclosure will require less amplifier power to achieve a given acoustic output (down to the enclosure's resonance frequency) than in an optimum sealed enclosure.

VENTED-ENCLOSURE PERFORMANCE TRADE-OFFS

- Reduced output in the lowest octave (below 40Hz).
- Reduced mechanical power handling below the enclosure's resonance frequency. The use of an electronic infrasonic filter is strongly recommended, to reduce the chance of overdriving the subwoofer below the enclosure's resonance frequency.
- An optimum vented enclosure will always be larger than an optimum sealed enclosure.

VENTED-ENCLOSURE CONSTRUCTION

Vented-enclosure construction is more difficult than the construction of a sealed enclosure. The enclosure volume and port dimensions have a specific relationship with the physical and electromechanical characteristics of the subwoofer, requiring that the recommended enclosure volume and port characteristics be strictly observed. As with sealed enclosures, use medium-density fiberboard (MDF), glue and screws to construct the enclosure, and seal all joints with silicone caulk.

THE INFINITY RECOMMENDATION

1000s and 1200s subwoofers in vented enclosures are recommended for enthusiasts who prefer accentuated bass response, for those who have plenty of cargo space to devote to a subwoofer enclosure and for those who will use a less powerful amplifier to drive their subwoofer. The volume and port dimensions indicated on the included technical data sheet must be followed precisely to ensure optimum performance.

BAND-PASS ENCLOSURES

Band-pass enclosures can provide the most output from any amplifier and subwoofer combination over a limited band of frequencies, but that additional output comes at the expense of sonic accuracy. Band-pass enclosures combine a sealed or vented enclosure that houses the subwoofer along with a vented chamber into which the subwoofer outputs its sound. The vented chamber acts as an acoustic low-pass filter which attenuates high frequencies in the subwoofer's output. That attenuation of high frequencies can make it very difficult to hear amplifier and speaker distortion; consequently, you may not be able to determine when the subwoofer is in danger of being damaged.

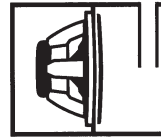

See accompanying data sheet for specific enclosure dimension requirements.

BAND-PASS-ENCLOSURE PERFORMANCE ADVANTAGES

- An optimum band-pass enclosure provides higher output over a limited bandwidth than an optimum enclosure of any other type.

BAND-PASS-ENCLOSURE PERFORMANCE TRADE-OFFS

- Band-pass enclosures achieve high output at the expense of sonic accuracy.
- An optimum band-pass enclosure has a more limited bandwidth than an optimum enclosure of any other type.
- The enclosure's low-pass filter characteristics can make it difficult to hear if the subwoofer is in danger of being damaged.
- An optimum band-pass enclosure is usually larger than an optimum vented enclosure.

BAND-PASS-ENCLOSURE CONSTRUCTION

Band-pass-enclosure construction is more difficult than vented-box construction and, as with vented enclosures, the design parameters for the vented section must be followed carefully. (The sealed section is more forgiving of small design and construction variations.) Fortunately, there are many prefabricated band-pass enclosures that are designed to extract the most output possible from nearly any subwoofer. Prefabricated band-pass enclosures are strongly recommended if you must have a band-pass enclosure. If you choose to build your own band-pass enclosure, use medium-density fiberboard (MDF), glue and screws to construct the enclosure, and be sure to seal all joints with silicone caulk.

THE INFINITY RECOMMENDATION

Band-pass enclosures are recommended only for enthusiasts who want high sound-pressure levels (SPL) without regard for sonic accuracy. If high SPL AND great-sounding bass are your goals, choosing a vented enclosure is recommended instead.

REFERENCE[®]

EN

MOUNTING THE SUBWOOFER

The 1000s and 1200s subwoofers can be mounted from the outside of the enclosure or from the inside of the enclosure. Whichever way you mount the subwoofer, use the included foam mounting gasket to ensure a leak-free seal between the subwoofer frame and the enclosure.

CONNECTING THE SUBWOOFER

SETTING THE IMPEDANCE

The 1000s and 1200s subwoofers both feature the Selectable Smart Impedance™ (SSI) switch. This exclusive feature lets you set the subwoofer's impedance to either 2 ohms or 4 ohms with the flip of a switch (see illustrations to the right). This allows you to extract the most from your subwoofer amplifier in any situation.

The SSI 2-ohm setting increases the subwoofer's output over the 4-ohm setting by up to 3dB, depending on the amplifier. Performance is identical in all

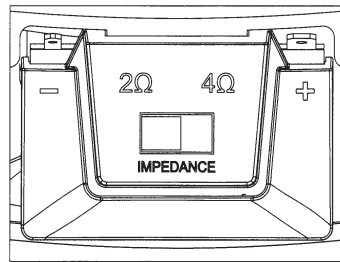

2-Ohm Setting

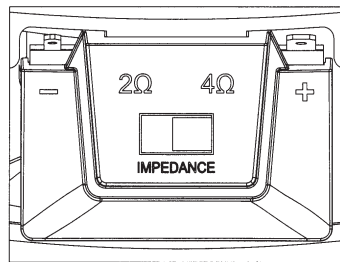

4-Ohm Setting

other respects. If the connected amplifier is rated for 2-ohm operation and its 2-ohm power ratings are within the subwoofer's power-handling specifications, setting the SSI switch in the 2-ohm position will achieve maximum output.

IMPORTANT: Make sure the subwoofer amplifier is turned OFF before setting the SSI switch. Do not change the switch position while the subwoofer amplifier is operating. Doing so could damage the amplifier.

CONNECTING THE AMPLIFIER

The Reference 1000s and 1200s subwoofer connectors are compatible with quick-disconnect (not supplied) or soldered connections. The recommended wire gauge is between 14AWG and 8AWG, depending on the length of the wire run between the amplifier and woofer. Heavier gauge wire is preferred for runs over 6' (2m).

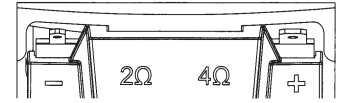

The wider terminal is the positive and the narrower is negative (also indicated on the terminal cover).

NOTE: If using untinned bare wire, be sure that no stray "+" and "-" strands touch each other. Touching strands can cause a short circuit, which can damage your amplifier.

SPECIFICATIONS

	1000s 10" (250mm) Low-profile SSI Automotive Subwoofer	1200s 12" (300mm) Low-profile SSI Automotive Subwoofer
Power Handling (RMS):	200W	250W
Power Handling (Peak):	800W	1000W
Sensitivity @ 2.83V/1m:	89dB	92dB
Frequency Response:	35Hz – 175Hz	27Hz – 175Hz
Impedance:	2 or 4 ohms (selectable)	2 or 4 ohms (selectable)
Voice-Coil Diameter:	2" (50mm)	2" (50mm)
Mounting Depth:	3-5/16" (83mm)	3-5/16" (83mm)
Overall Diameter:	10-9/16" (268mm)	12-1/4" (310mm)
Cutout Diameter:	9-1/2" (240mm)	11-1/8" (282mm)

A valid serial number is required for warranty coverage.

Features, specifications and appearance are subject to change without notice.

These products are designed for mobile applications and are not intended for connection to the mains.

HARMAN

HARMAN International Industries, Inc. 8500 Balboa Boulevard, Northridge, CA 91329 USA
www.infinetyspeakers.com

© 2014 Harman International Industries, Incorporated. All rights reserved.

Infinity and Reference are trademarks of Harman International Industries, Incorporated, registered in the United States and/or other countries.

Infinity



REFERENCE 1000s 10" WOOFER – TECHNICAL DATA



THIELE-SMALL PARAMETERS

	2Ω	4Ω
VOICE-COIL DC RESISTANCE:	REVC (OHMS) 1.80	4.09
VOICE-COIL INDUCTANCE @ 1kHz:	LEVC (MH) 0.65	0.72
DRIVER RADIATING AREA:	SD (IN2) 54.72	54.72
	SD (CM2) 353.00	353.00
MOTOR FORCE FACTOR:	BL (TM) 9.05	12.97
	VAS (FT3) 1.20	1.18
COMPLIANCE VOLUME:	VAS (LITERS) 34.03	33.47
	CMS (μM/N) 194.00	191.00
MOVING MASS, AIR LOAD:	MMS (GRAMS) 145.01	145.64
FREE-AIR RESONANCE:	FS (Hz) 29.97	30.16
MECHANICAL Q:	QMS 8.64	4.52
ELECTRICAL Q:	QES 0.62	0.69
TOTAL Q:	QTS 0.57	0.59
MAGNETIC-GAP HEIGHT:	HAG (IN) 0.31	0.31
	HAG (MM) 8.00	8.00
VOICE-COIL HEIGHT:	HVC (IN) 0.92	0.92
	HVC (MM) 23.30	23.30
MAXIMUM EXCURSION:	XMAX (IN) 0.30	0.30
	XMAX (MM) 7.65	7.65

SPECIFICATIONS

DIAMETER:	10" (254MM)
SENSITIVITY (2.83V @ 1m):	89dB
POWER HANDLING:	200W _{RMS} (800W _{PEAK})
FREQUENCY RESPONSE:	35Hz ~ 175Hz
NOMINAL IMPEDANCE:	2 OR 4 OHMS
VOICE-COIL DIAMETER:	2" (51MM)
DIMENSIONS:	

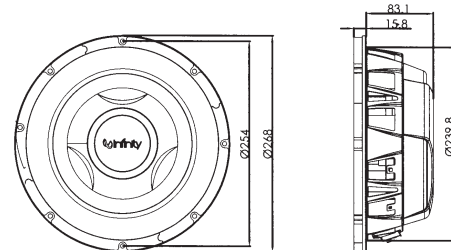

SEALED-BOX VOLUME (INCLUDES DRIVER DISPLACEMENT)

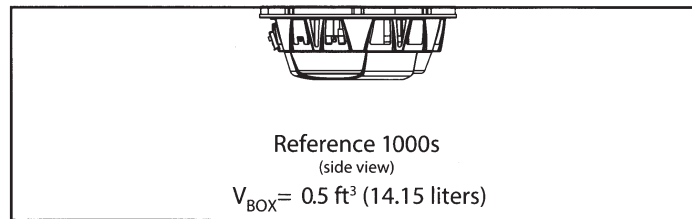

SEALED ENCLOSURE (FREQUENCY RESPONSE @ 2.83V)

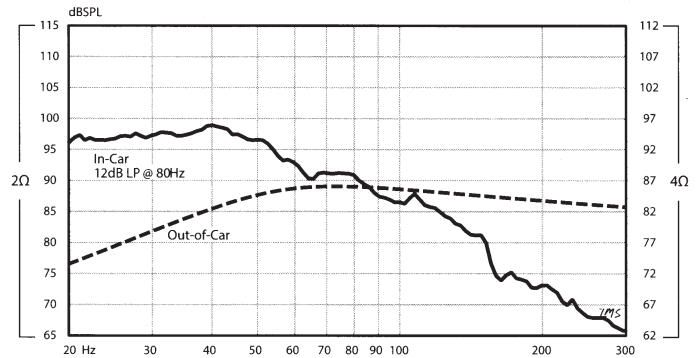

VENTED-BOX VOLUME (INCLUDES DRIVER/PORT DISPLACEMENTS)

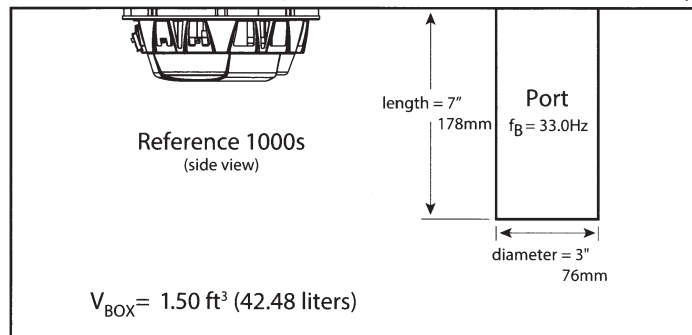

VENTED ENCLOSURE (FREQUENCY RESPONSE @ 2.83V)

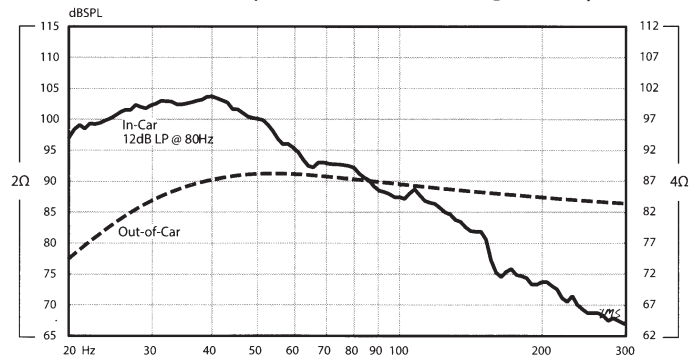

BAND-PASS-BOX VOLUME (INCLUDES DRIVER/PORT DISPLACEMENTS)

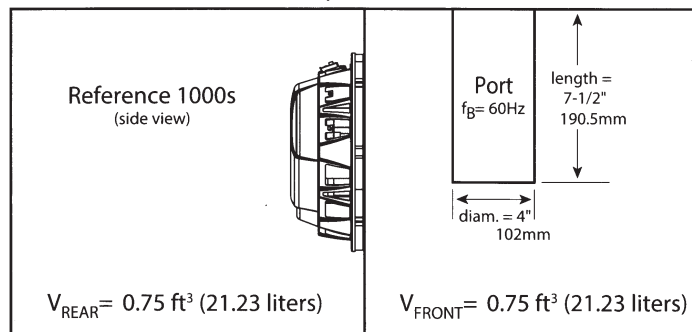

BAND-PASS ENCLOSURE (FREQUENCY RESPONSE @ 2.83V)

