

SOUNDSTREAM



Picasso
NANO

Class D Audio Amplifier

Owner's Guide

PN4.320D PN4.520D PN1.450D PN1.650D
PN2.350D PN5.640D

Features PN2.350D

- Class-D Digital Full range 2ohm stable stereo.
- Applying new concept "Low-Heat Producing Circuit".
- Tri-mode capable.
- Channel Design 3 /2 Channels.
- Full MOSFET DC-DC PWM Power Supply.
- Four way protection.
- Double Sided FR-4 PC Board.
- SMD Technology.
- High level input connector (Auto turo ON).
- Crossover: Adjustable Low-Pass,Hi-pass, Bass boost.
- NI Plated RCA Input Connectors.
- NI 4Guage Input Block type Power Terminal and 4Guage out Speaker Block type Terminals.
- Variable low pass remote dashes mount gain control.
- Ultra slim size.

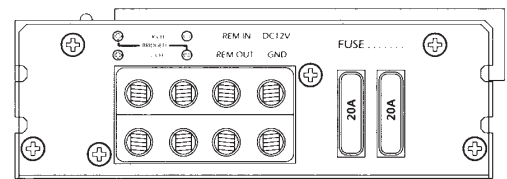
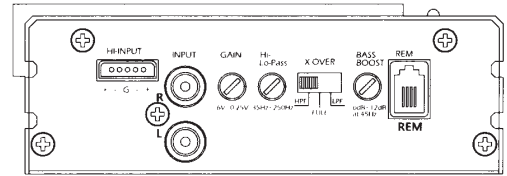

Features PN4.320D PN4.520D

- Class-D Digital Full range 2ohm stable stereo.
- Applying new concept "Low-Heat Producing Circuit"
- Tri-mode capable.
- Channel Design 4/3 /2 Channels.
- Full MOSFET DC-DC PWM Power Supply.
- Four way protection.
- Double Sided FR-4 PC Board.
- SMD Technology.
- High level input connector (Auto turo ON).
- Fixed Low-Pass (80Hz) / High-Pass,(80Hz).
- NI Plated RCA Input Connectors.
- Connector Terminals: NI 4Guage Input Block type Power Terminal and 4Guage out Speaker Block type Terminals.
- Ultra slim size.

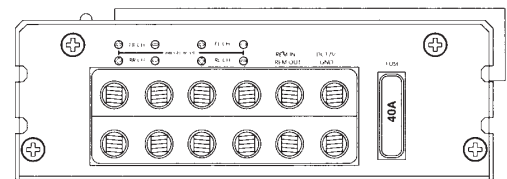
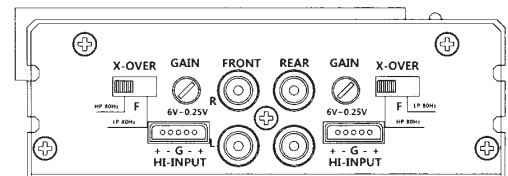

Features PN5.640D

- Class-D Digital Full range 2ohm stable stereo.
- Applying new concept "Low-Heat Producing Circuit".
- Channel Design 5/4/3Channels.
- Full MOSFET DC-DC PWM Power Supply.
- Four way protection.
- Double Sided FR-4 PC Board.
- SMD Technology.
- Variable low pass remote dashes mount gain control.
- RCA Connector.
- High level input connector (Auto turn ON).
- Adjustable Low-Pass, hi-pass, Bass boost.
- Adjustable Gain Control.
- NI 4Guage Input Block type Power Terminal and 4Guage out Speaker Block type Terminals.
- Ultra slim size.

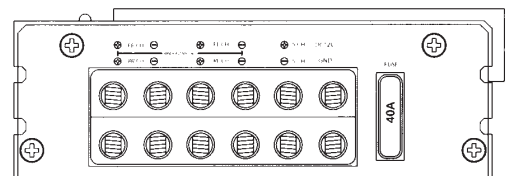
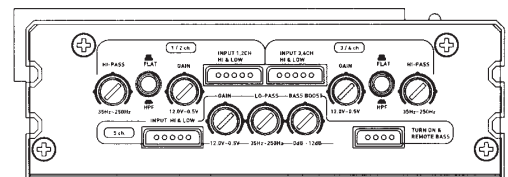

Features PN1.450D PN1.650D

- Class-D Mono block 2ohm stable.
- Applying new concept "Low-Heat Producing Circuit".
- Channel Design 1 Channel. (Mono)
- Full MOSFET DC-DC PWM Power Supply.
- Four way protection.
- Double Sided FR-4 PC Board.
- SMD Technology.
- High level input connector.
- Variable low pass remote dashes mount gain control.
- NI Plated RCA Input Connectors.
- Adjustable Low-Pass, Bass boost, Sub sonic.
- Adjustable Gain Control.
- NI 4Guage Input Block type Power Terminal and 4Guage out Speaker Block type Terminals.
- Ultra slim size.

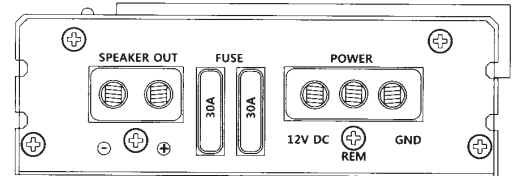
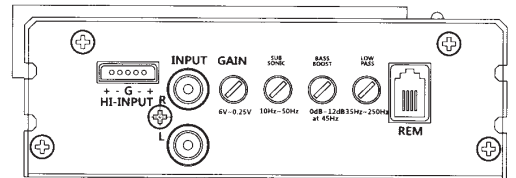

POWER RATINGS	PN2.350D	PN4.320D	PN4.520D	PN5.640D	PN1.450D	PN1.650D
RMS Power 4 Ω , 14.4V	115w x 2	60w x 4	100w x 4	60w x 4ch + 200w	260w x 1	400w x 1
RMS Power 2 Ω , 14.4V	117w x 2	80w x 4	130w x 4	80w x 4ch + 350w	450w x 1	650w x 1
RMS Power 4 Ω Bridged, 14.4V	350w x 1	160w x 2	260w x 2	160w x 2ch + 350w	-	-
Dimensions (4.75"w x 1.5"h)	5.5"	7"	9.25"	10.3"	7"	9.25"

Power Connections

It is important to have good quality power and ground connections. Remember, to complete an electrical circuit, the ground connection is just as important as the positive power connection. Before any power connections are made, disconnect the ground cable of the battery. Use 8 gauge or larger automotive grade wire if the distance from the battery to the amp is excessive. Avoid sharp or rough edges as a safeguard against short circuiting and potential fire hazards.

GND = Connect the proper gauge ground wire to the amplifier GND terminal. Locate the position on the chassis of the car where the amplifier will be grounded. Use solder or a crimped ring terminal to connect the ground wire. Pre-drill the prepped chassis to bolt the ground ring terminal with a nut, bolt, and lock washer. Insulate the metal and the connector with paint or silicone to prevent rust and oxidation. Silicone also works great to prevent nuts and bolts from working loose in harsh environments of an automobile. Upon completion of the ground connection, grab the wire and connector to confirm the connection is solid. To prevent engine noise, it is recommended to ground the head unit and other electronic audio devices to the same location.

REM = Connect the remote wire (power antenna output) from the head unit to the REM terminal. If the head unit is not equipped with a remote/antenna output, locate a wire that is controlled by the accessory position of the key. It is important to have the amplifier turn off with the radio or key. If the amplifier remains on, the battery will drain.

12V = Connect the proper gauge power wire to the B+ terminal. Trace the power wire through the car to the in-line fuse or circuit breaker that is no more than 18" from the battery. Remember, the in-line fuse or circuit breaker protects the car in the event of short circuit. Connect the in-line fuse or circuit breaker to the battery, but do not install the fuse or activate the circuit breaker yet.

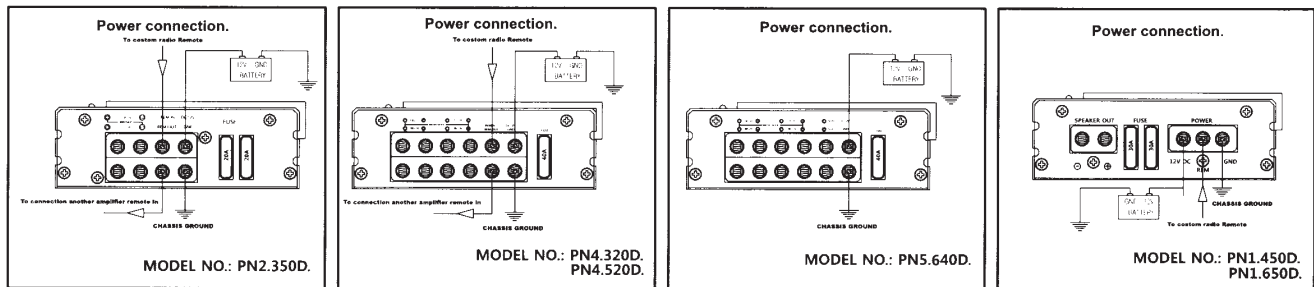

High Level input connections

The high level inputs are for use with speaker level wiring. Most factory source units do not have RCA outputs. Use this connection if your source unit does not have RCA outputs.

CAUTION: Never use the high and low level inputs at the same time!

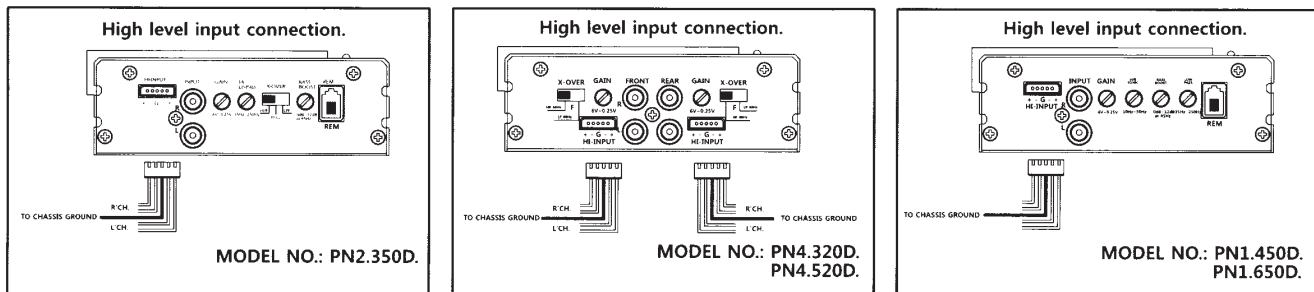

Speaker out connection.

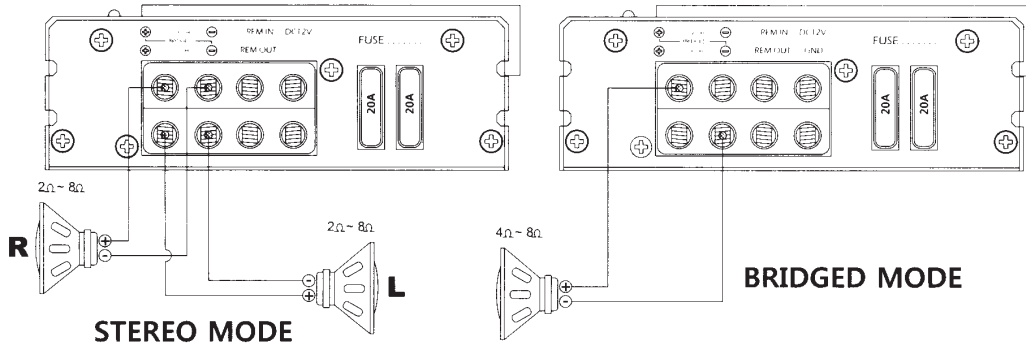

MODEL NO.: PN2.350D.

Speaker out connection.

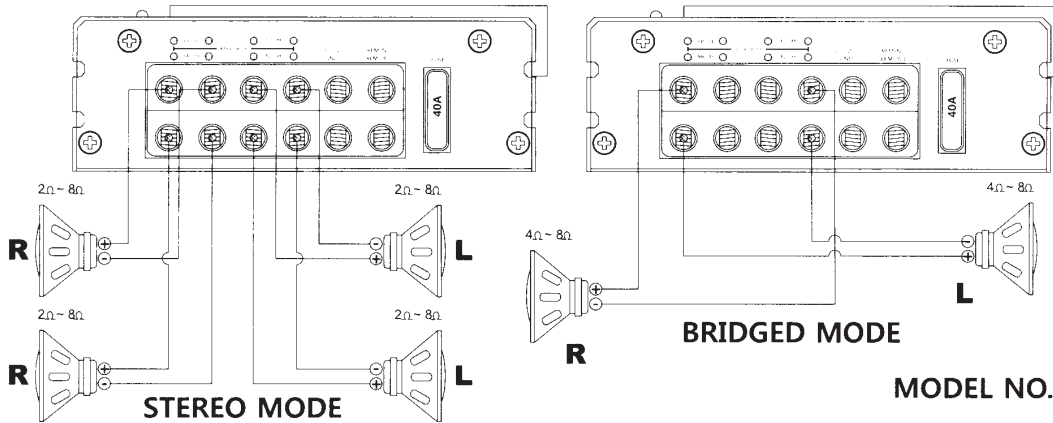

MODEL NO.: PN4.320D.
PN4.520D.

Speaker out connection.

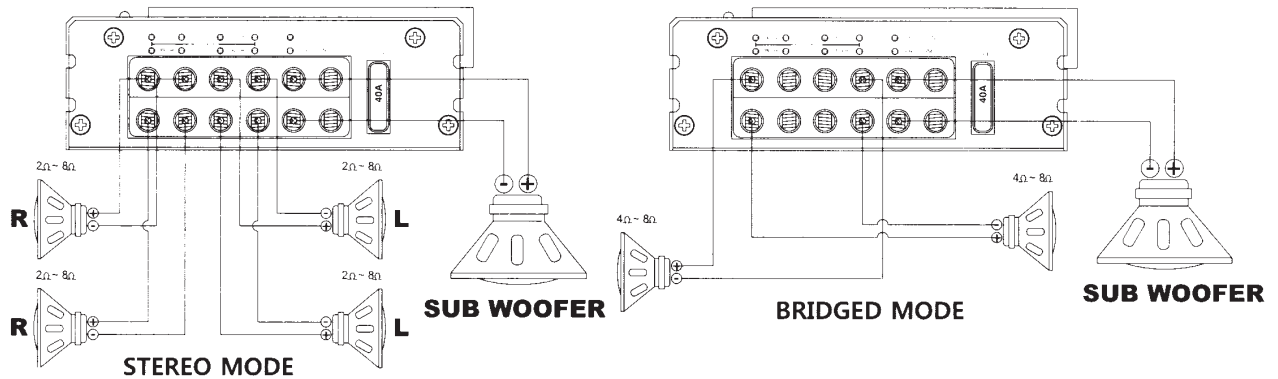

MODEL NO.: PN5.640D.

Speaker out connection.

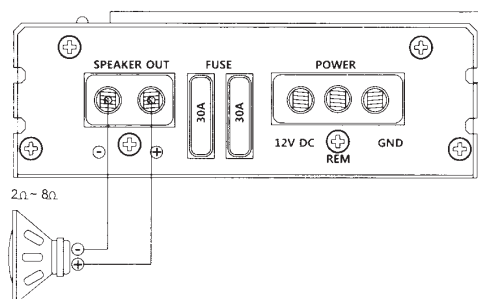

MODEL NO.: PN1.450D.
PN1.650D.

PICASSO NANO PRE-AMP FEATURES

1. Remote Level Control Connection

Connect the remote level control to this terminal. The remote level control allows adjustment of the subwoofer level from a remote location in the vehicle.

2. Low Pass Crossover

Adjust the frequency setting of the low pass crossover. The frequency range is 35Hz-250Hz. Frequencies higher than the setting will be filtered out of the audio signal.

3. Subsonic Crossover

Adjust the frequency setting of the subsonic crossover. The frequency range is 10Hz-50Hz. Frequencies lower than the setting will be filtered out of the audio signal.

4. Power & Protection Indicator LED

When the amplifier is on and in proper working condition, the green LED will illuminate. Refer to the Troubleshooting Guide for possible solutions if the amplifier will not power on. If the amplifier activates its protection mode, the red LED will illuminate. Refer to the Troubleshooting Guide for possible solutions if the amplifier activates its protection mode.

5. Level Sensitivity

Adjust the amplifiers pre-amp sensitivity level. The minimum sensitivity level is 250mv, while the maximum level is 6V.

6. RCA Audio Input Connection

Using high quality shielded stereo RCA cables, connect the source signal to the amplifier RCA inputs.

7. High Level Input

Connect the speaker outputs from the head unit to the high level input if RCA outputs are not available. NEVER use high level and RCA inputs at the same time.

8. Bass Boost

Adjust the amplifiers 45Hz Bass Boost level up to 12dB.

9. Crossover Selection Switch

Choose an 80Hz fixed frequency high pass crossover, 80Hz fixed frequency low pass crossover, or full range operation.

10. Variable High Pass Filter 35Hz~250Hz

For use as a dedicated mid high range channel, set filter switch to "HIGH PASS". The Input circuit filters out all frequencies below 35Hz~250Hz

11. The 5 channel amplifier will be activated remote trigger input with bass control unit on the 3.5 pie port same time in the mode. It requires connect remote trigger input on power input connector section to turn on the amplifier if user won't need to connect the bass control unit

Note : Remote trigger input power must be connected well tight and firmly on the 3.5 pie port, Amplifier won't be able to turn on if its loosen or not connected.

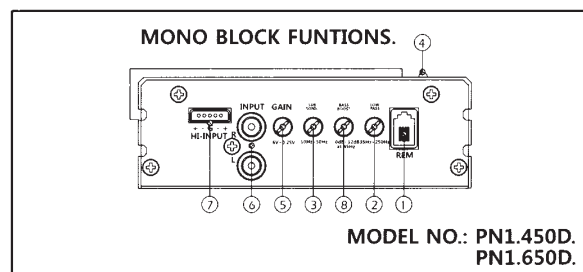
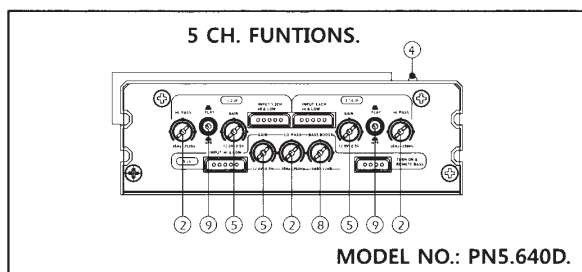
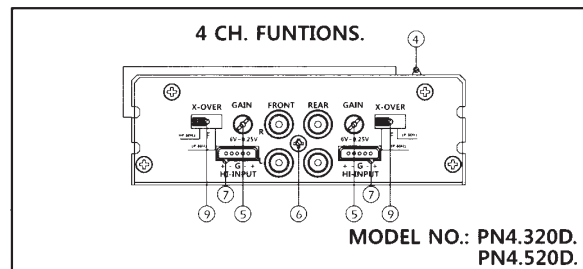
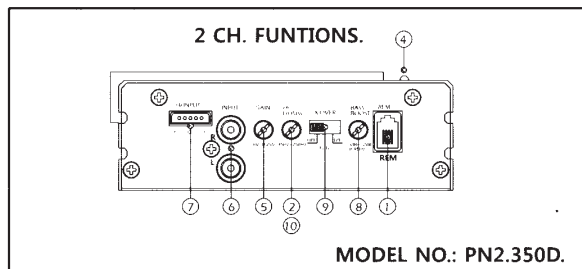

Mounting Your Picasso Nano

Choosing the best mounting location for your Picasso Nano amplifier is crucial. The amplifier should be mounted to any wood, metal, or carpeted surface. The heatsink can be mounted directly to the chassis of the car, or isolated for best performance. It needs proper ventilation, so avoid mounting the amp under seats, in the engine bay, or any other area that moisture might accumulate. Be sure the mounting screws do not penetrate the fuel tank, brake lines, or any other crucial fluid lines. Never mount the amplifier to a subwoofer enclosure, as excessive vibrations can cause damage.

Warning

Soundstream highly recommends that an in-line fuse or circuit breaker be installed within 18" of the battery. Although your Picasso Nano amplifier has adequate internal protection, it is possible a damaged wire between the component and the battery may result in a fire. The in-line fuse or circuit breaker should be installed in a location that is easy to access, and all wiring should be routed safely, following the below suggestions:

- Avoid placing wires near hot or moving objects
- Always use wire grommets when routing wire through the firewall or any other metal surfaces
- Avoid the potential for damaged wires by routing all wires away from moving hinges, seats, brake & gas pedals, hood and trunk hinges, etc.

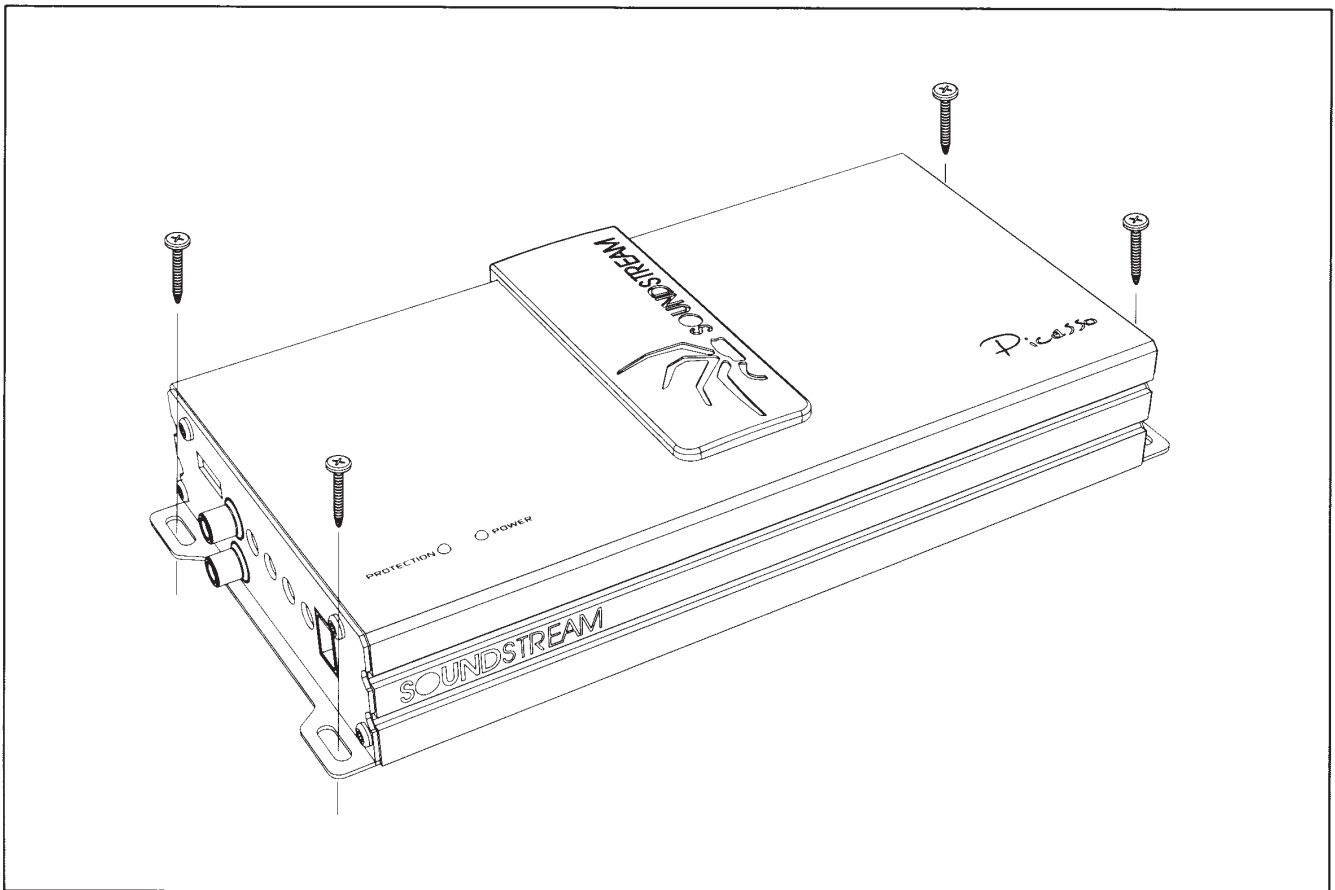

Setting the gains:

It is a fact that very few people, including professional installers, know how to set gains correctly. Failure to do so yields higher distortion, a higher noise floor which decreases dynamic headroom, less than optimum operating conditions for electronic equipment, and higher failure rate for both the electronic equipment and transducers alike.

While most people set this control by ear to how loud they want their music, this is not the intent of this control. The range is from 0.25 volts to 6 volts. The control is meant for matching the output of the source unit's signal voltage. For example, if you have a source unit with low output voltage, you would probably have the control set fairly high, towards the 0.25V range. A lot of head units have 4 volts of output signal voltage which means that your control would be set midway through the range. If you happen to have a line driver (signal booster) that yields 6 volts or more, you will set the gain at the minimum position, towards the 6V range.

In all of these examples, when properly level matched, the amplifier will put out full volume. Setting the control above the proper point may cause damage to the amplifier and speakers, and can result in poor sound quality and overall undesirable results.

Bass Boost control:

The monoblock amplifiers feature a variable Bass Boost control, centered at 45Hz. You can adjust the amount of boost from 0dB to 18dB.

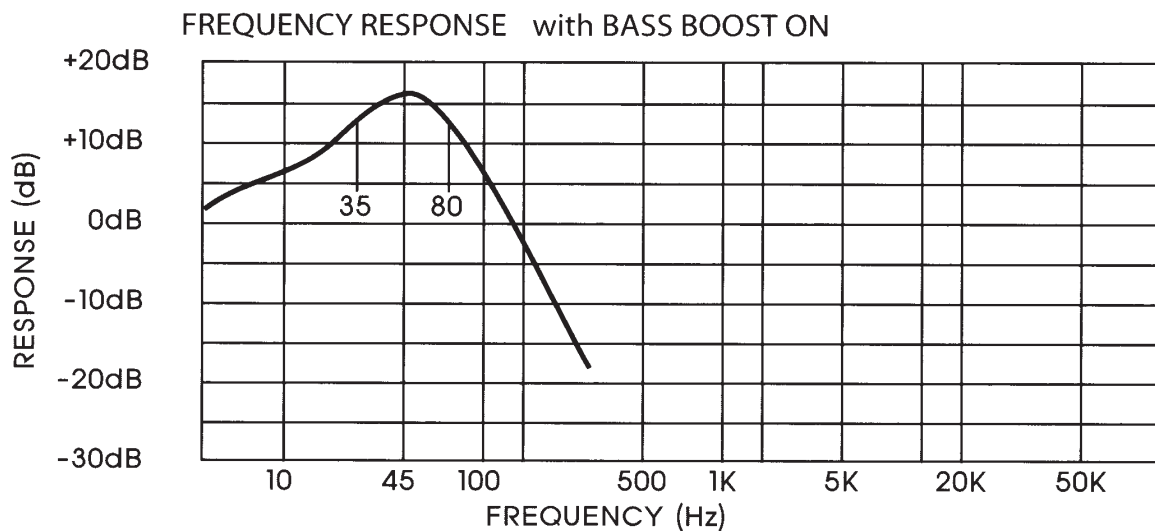

Trouble shooting.

SYMPTOMS	CHECK	REMEDY
NO SOUND	Is the power LED illuminated? (NO)	Check all fuses to amplifier. Be sure Turn-on lead is connected Check signal leads. Check gain control. Check Tuner/Deck volume level. Clean contacts on fuse holders.
	Is the Diagnostic LED illuminated? (YES)	Check for speaker short or amplifier overheating.
AMP NOT SWITCHING ON	No power to power wire	Repair power wire or connections.
	No power to remote wire with receiver on	Check connections to radio.
	Burnt or broken fuse	Replace fuse
NO SOUND, ON ONE CHANNEL	Check Speaker Leads	Inspect for short circuit or an open connection.
	Check Audio Leads	Reverse Left and Right RCA inputs to determine if the problem is occurring before the amp.
AMP TURNING OFF MEDIUM/HIGH VOLUME	Check Speaker load impedance	Be sure proper speaker load impedance recommendations are observed. (If you use an ohmmeter to check speaker resistance, please remember that DC resistance and AC impedance may not be the same.)
PROTECTION LAMP ON	Shut down	Turn radio down Wait for AMP to cool
	Speaker wires shorted	Separate speaker wires and insulate

Warning

Investigate the layout of your vehicle before drilling or cutting any holes. Take care when you are working near the gas tank, brake lines, hydraulic lines, and electrical wiring. Do not use the amplifier without securely mounting it, as the amp or vehicle may be damaged in the event of an accident. Do not mount the amplifier where the wire connections are unprotected or are subject to pinching or damage from other vehicle components. The 12V power wire must be fused within 18" of the battery. Ensure the source unit is powered off before making any wiring connections. If you need to replace the fuses, use only the same type and size. Using a fuse of a different type or rating may result in damage to the amplifier or vehicle, which will not be covered under the manufacturer's warranty.



LIMITED 90-DAY CONSUMER WARRANTY

LIMITED TWO-YEAR CONSUMER WARRANTY WITH PURCHASE AND INSTALLATION BY A SOUNDSTREAM AUTHORIZED DEALER

Soundstream promises to the original purchaser, to repair or replace this product with a new or refurbished unit (at Soundstream's sole and absolute discretion) should it prove to be defective in workmanship or material under normal use, for a period of *two-years from the date of purchase from the Soundstream authorized dealer, PROVIDED the product was purchased and installed by a Soundstream authorized dealer. During this *two-year period, there will be no charge for product repair or replacement, PROVIDED the unit is returned to Soundstream, return shipping pre-paid, along with the required proof of installation, the bill of sale or other dated proof of purchase, and the consumer's contact information.

If the unit is installed by anyone other than a Soundstream authorized dealer, the warranty period will be 90-days from the date of purchase. This warranty is non-transferable and does not apply to any unit that has been modified or used in a manner contrary to its intended purpose, and does not cover damage to the unit caused by installation or removal of the unit. During this 90-day period, there will be no charge for the repair or replacement PROVIDED the unit is returned to Soundstream, return shipping prepaid, along with the bill of sale or other dated proof of purchase and the consumer's contact information.

This warranty is void if the product has been damaged by accident or unreasonable use, neglect, improper service or other causes not arising out of defects in materials or construction. This warranty does not cover the elimination of externally generated static or noise, or the correction of antenna problems or weak reception, damage to speakers, accessories, electrical systems, cosmetic damage or damage due to negligence, misuse, failure to follow operating instructions, accidental spills or customer applied cleaners, damage due to environmental causes such as floods, airborne fallout, chemicals, salt, hail, lightning or extreme temperatures, damage due to accidents, road hazards, fire, theft, loss or vandalism, damage due to improper connection to equipment of another manufacturer, modification of existing equipment, or Product which has been opened or tampered for any reason. Units which are found to be damaged by abuse resulting in thermally damaged voice coils are not covered by this warranty but may be replaced at the absolute and sole discretion of Soundstream. Unit must be returned to Soundstream, postage pre-paid, with bill of sale or other dated proof of purchase bearing the following information: consumer's name, telephone number, and address, authorized dealer's name and address, and product description. Please contact Soundstream warranty office at 800-724-1377 or repairs@soundstream.com to obtain a Return Authorization number prior to shipping the product.

Note: This warranty does not cover labor costs for the removal and reinstallation of the unit. IN ORDER FOR THE TWO-YEAR WARRANTY TO BE VALID, YOUR UNIT MUST BE SHIPPED WITH PROOF OF INSTALLATION BY A SOUNDSTREAM AUTHORIZED DEALER. ALL UNITS RECEIVED BY SOUNDSTREAM FOR WARRANTY REPAIR WITHOUT PROOF OF SOUNDSTREAM AUTHORIZED DEALER INSTALLATION AND PURCHASE WILL BE COVERED BY THE LIMITED 1 YEAR WARRANTY.

BY PURCHASING THIS PRODUCT, ALL WARRANTIES INCLUDING BUT NOT LIMITED TO EXPRESS WARRANTY, IMPLIED WARRANTY, WARRANTY OF MERCHANTABILITY, FITNESS FOR PARTICULAR PURPOSE, AND WARRANTY OF NON-INFRINGEMENT OF INTELLECTUAL PROPERTY ARE EXPRESSLY EXCLUDED TO THE MAXIMUM EXTENT ALLOWED BY LAW, AND SOUNDSTREAM NEITHER ASSUMES NOR AUTHORIZES ANY PERSON TO ASSUME FOR IT ANY LIABILITY IN CONNECTION WITH THE SALE OF THE PRODUCT. SOUNDSTREAM HAS ABSOLUTELY NO LIABILITY FOR ANY AND ALL ACTS OF THIRD PARTIES INCLUDING ITS AUTHORIZED DEALERS OR INSTALLERS. BY PURCHASING THIS PRODUCT, THE CONSUMER AGREES AND CONSENTS THAT ALL DISPUTES BETWEEN THE CONSUMER AND SOUNDSTREAM SHALL BE RESOLVED IN ACCORDANCE WITH CALIFORNIA LAWS IN LOS ANGELES COUNTY, CALIFORNIA.

Some states do not allow limitation on how long an implied warranty lasts. In such states, the limitation or exclusions of this Limited Warranty may not apply. Some states do not allow the exclusion or limitation of incidental or consequential damages. In such states, the exclusion or limitation of this Limited Warranty may not apply to you. This Limited Warranty gives you specific legal rights, and you may have other rights which vary from state to state.



Please Keep This Information For Your Records

Product Model: _____

Serial Number: _____

Date Purchased: _____

Name of Dealer: _____

Dealer Address: _____

City: _____ State: _____ Zip: _____

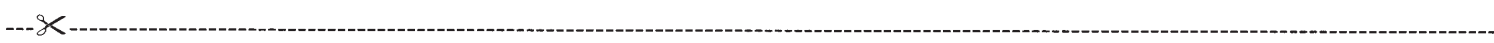

SoundStream Technologies
1550 S. Maple Ave.
Montebello, CA 90640
Attn. Customer Service



SOUNDSTREAM

T E C H N O L O G I E S

SoundStream Technologies warrants this product to be free from defects in materials and workmanship under normal use and conditions, for a period of 1 year from the original date of purchase, if purchased and professionally installed by an Authorized SoundStream dealer. Any product purchased from and/or installed by others will be warranted for 90 days only. This warranty does not cover any expenses incurred in the removal or re-installation of the product, and is offered to the original purchaser only.

Should service be necessary for any reason, due to a manufacturing defect or malfunction during the warranty period, SoundStream Technologies will repair or replace, at its discretion, the defective merchandise at no charge upon delivery of the product to the address shown below, with proof of purchase. Before returning the product for service:

- Enclose with the defective product a brief description of the problem with a name and daytime phone number so we may be in contact with any questions or concerns regarding the return.
- Enclose a copy of the original sales receipt for proof of purchase and installation.
- Enclose a \$15.00 US certified check or money order to cover shipping and handling for return of the product. Do not include cash.

Carefully pack the product to protect it from damage during shipping and send it prepaid to:

SoundStream Technologies
1550 S. Maple Ave.
Montebello, CA 90640
Attn. Customer Service

Ph: 800-724-1377 Fax: 323-722-8125

Please note, the warranty will not cover the following:

- Any product that has been misused or physically damaged.
- Any product that has been installed incorrectly. (i.e. over powered, incorrect enclosure, incorrect wiring, etc.)
- Any units that have been previously opened or repaired by a service center which is not authorized by SoundStream Technologies.

Any applicable implied warranties, including the warranty of the merchants ability are limited in duration to a maximum of 2 years from the date of the original purchase at retail and no warranties, whether expressed or implied, shall apply to this product there after. Under no circumstances shall SoundStream Technologies be liable for any loss or damage, direct or consequential arising out of the use of, or inability to use this product. (some states do not allow for limitations of implied warranties or exclusion of consequential damage therefore these restrictions may not apply.) To receive the full benefit of this warranty, fill out the included warranty card and mail it to the address shown.



Owners Registration Card.

Please complete and return immediately to the address on the reverse side

Name: _____

Address: _____

City: _____ State: _____ Zip: _____

Vehicle Make/Model: _____

Product Model: _____

Serial Number: _____

Date Purchased: _____

Name of Dealer: _____

Dealer Address: _____

City: _____ State: _____ Zip: _____

Phone: _____ Website: _____



WWW.SOUNDSTREAM.COM

SOUNDSTREAM



Picasso
NANO



CLASS D SMT SURFACE MOUNT TECHNOLOGY PWM MOSFET POWER SUPPLY BALANCED SIGNAL INPUT HIGH LEVEL INPUT 12dB 12dB BASS BOOST BRIDGEABLE REMOTE GAIN MODULE

PN5.640D

5Ch. CLASS D DIGITAL AMPLIFIER

640W

SOUNDSTREAM.COM

Picasso NANO PN5.640D

5Ch. CLASS D DIGITAL AMPLIFIER
640W

Class D Digital Full Range Amplifier
Full MOSFET PWM Power Supply
SMD Technology on Double Sided PCB
8ga Power Terminals & 8ga Speaker Outputs
High & Low Level Signal Inputs
2-Ohm Stereo, 4-Ohm Bridged Stable
Remote Mount Gain Control Included

Variable 35Hz~250Hz 12dB High/Low Pass Filter
Variable 0-12dB 45Hz Bass Boost
60w x 4 + 200w @ 4-ohm
80w x 4 + 350w @ 2-ohm
160w x 2 + 350w @ 4-ohm Bridged
Total Harmonic Distortion: 0.5%
Frequency Response: 10Khz-35Khz

Signal-to-Noise Ratio: 70dB
Damping Factor: > 250
Stereo Channel Separation: < 55dB
Input Sensitivity: 0.5mV-12V
Dimensions: 4.75"w x 1.5"h x 10.3"L

SOUNDSTREAM.com



Made in Korea



Visit Us Facebook



SOUNDSTREAM

SOUNDSTREAM

MODEL NO.: PN5.640D PICASSO-Series

MADE IN KOREA

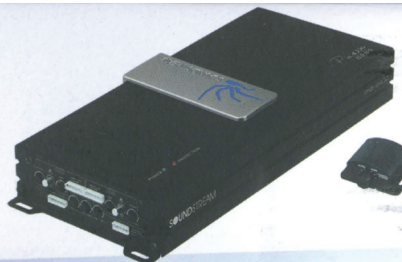

Picasso
NANO

SOUNDSTREAM.com

PN5.640D

5Ch. CLASS D DIGITAL AMPLIFIER
640W